

THIS DRAWING IS UNPUBLISHED. RELEASED FOR PUBLICATION
 © COPYRIGHT - BY TYCO ELECTRONICS CORPORATION. ALL RIGHTS RESERVED.

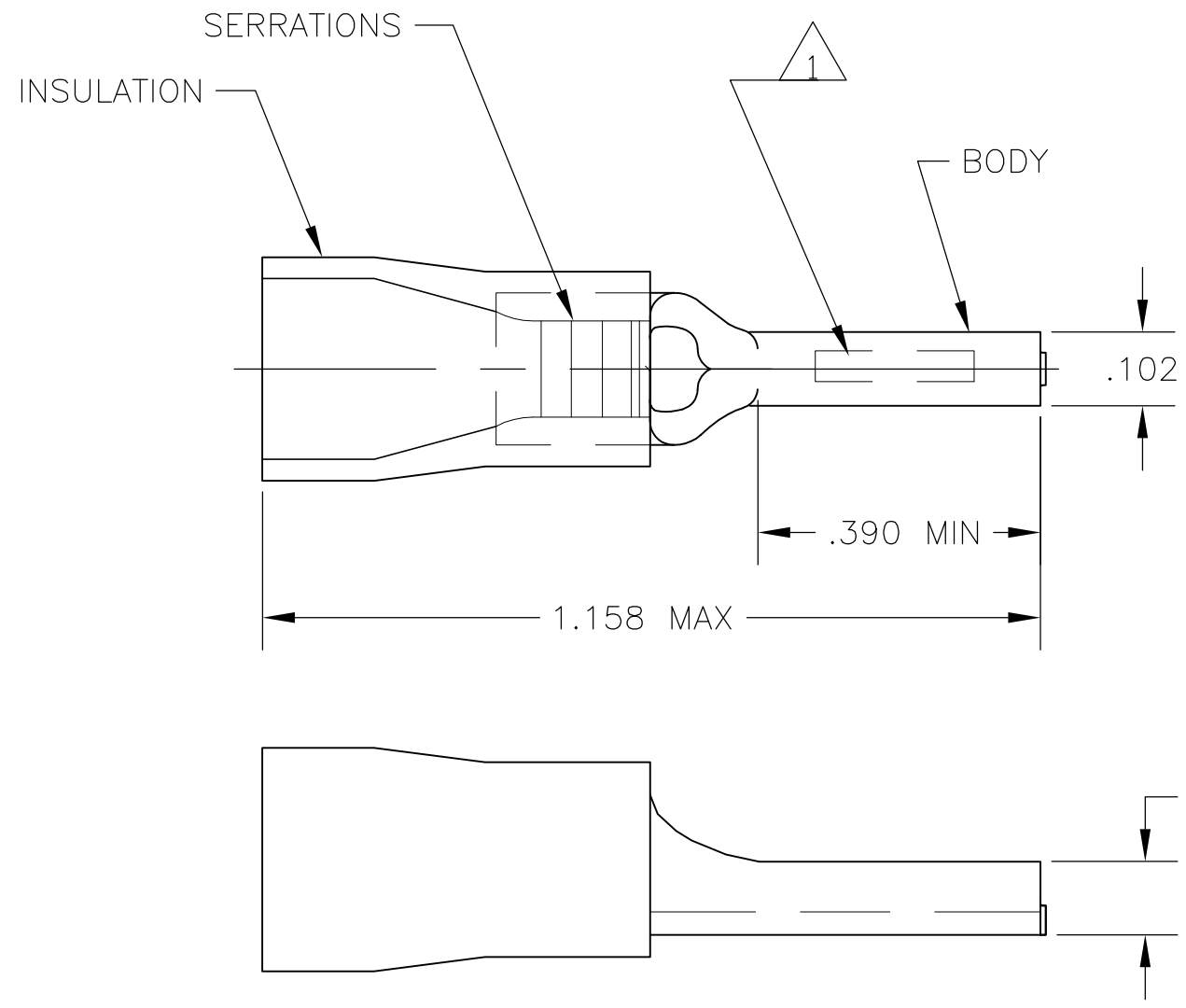

LOC	DIST	REVISIONS			
P	LTR	DESCRIPTION	DATE	DWN	APVD
G	14	C2	REV PER ECR 08-013669	29MAY08	JR TM

AMP WIRE RANGE	 Listed FILE E13288
12-10 AWG STRANDED	12-10 AWG STRANDED



- △1 STAMP AMP 12-10* APPROX AS SHOWN
- 2 WIRE INSULATION DIA: .150-.250
- 3 TONGUE MATERIAL THK: .039±.002
- △4 MATERIAL: BODY - CU PER ASTM B152
SLEEVE - PVC, COLOR - YELLOW
- △5 PRELIMINARY - NOT FOR PRODUCTION

2000	ON TAPE	△5 2-165085-1
500	LOOSE PIECE	165085
QTY	PACKAGE TYPE	PART NO.

AMP INCORPORATED CUSTOMER SERVICE SYSTEMS		MAX RECOMMENDED OPERATING TEMPERATURE: 105°C [221°F]	THIS DRAWING IS A CONTROLLED DOCUMENT.		DWN JR RUTH 23MAR07	 Tyco Electronics Corporation Harrisburg, PA 17105-3608	
FOR ADDITIONAL PRODUCT INFORMATION OR COPIES OF DRAWINGS AND TECHNICAL DOCUMENTS	PRODUCT INFORMATION CENTER 1-800-522-6752	VOLTAGE RATING: 600 V MAX	DIMENSIONS: INCHES	TOLERANCES UNLESS OTHERWISE SPECIFIED:	CHK T MICHIELUTTI 23MAR07	NAME TERMINAL, WIRE PIN, PLASTI-GRIP WIRE SIZE 12-10 AWG	
FOR APPLICATION TOOLING INFORMATION	TOOLING ASSISTANCE CENTER 1-800-722-1111	CIRCULAR MIL AREA: 2.62-6.64mm² [5,180-13,100] STRANDED		0 PLC ± - 1 PLC ± - 2 PLC ± .008 3 PLC ± - 4 PLC ± - ANGLES ± -	APVD T MICHIELUTTI 23MAR07	APPLICATION SPEC NOT AVAILABLE	SIZE A3
FOR ORDER ENTRY	1-800-526-5142	THIS DRAWING IS A CONTROLLED DOCUMENT FOR AMP INCORPORATED. IT IS SUBJECT TO CHANGE AND THE CONTROLLING ENGINEERING ORGANIZATION SHOULD BE CONTACTED FOR THE LATEST REVISION.	MATERIAL - △4	FINISH TIN PER ASTM B545	PRODUCT SPEC -	WEIGHT -	CAGE CODE 00779
					DRAWING NO C-165085		RESTRICTED TO -
					CUSTOMER DRAWING		SCALE 4:1
							SHEET 1 OF 1
							REV C2